

KXF200

Exploded parts diagram

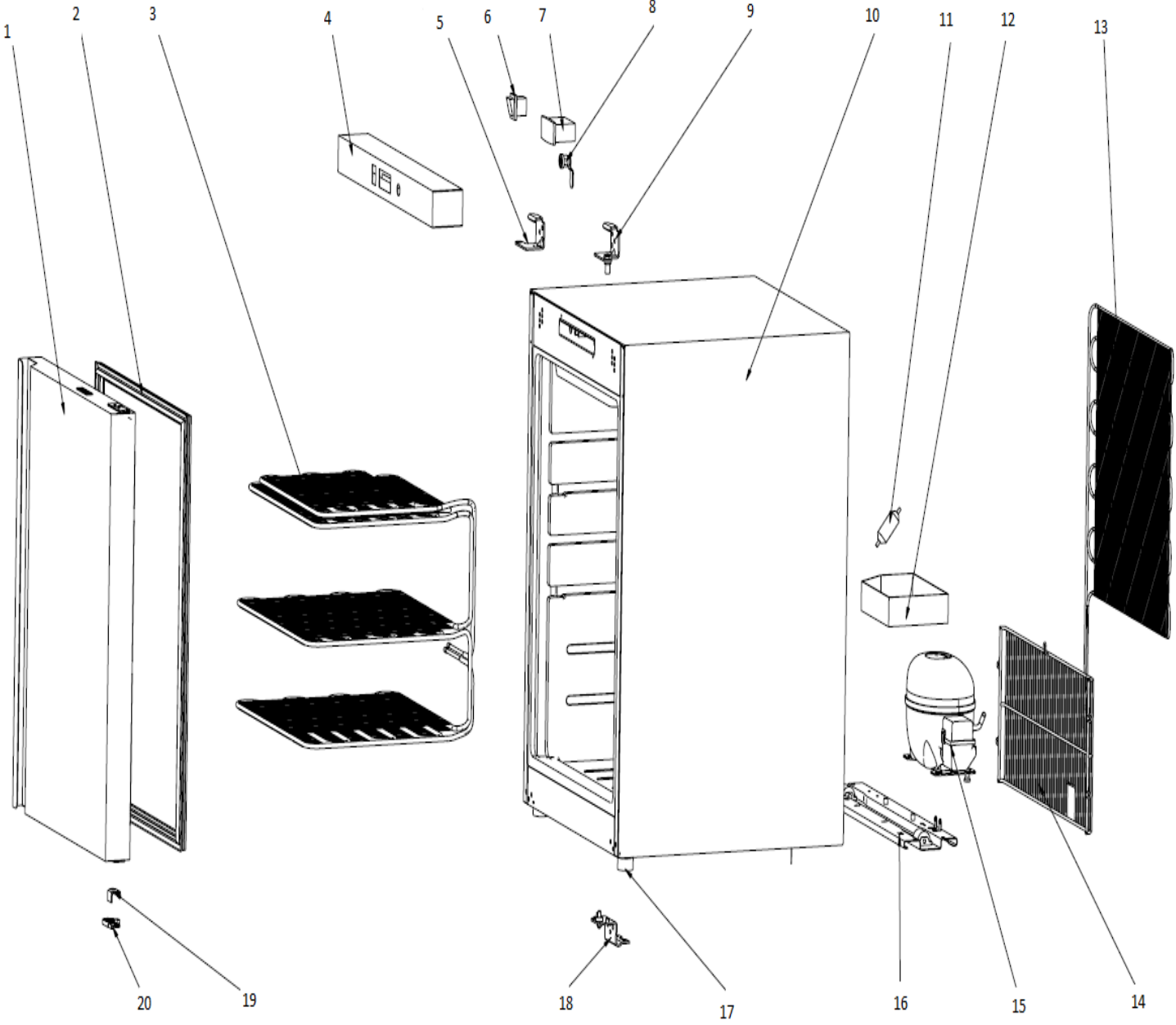





Part Number	number	name	quantity
V2-DOOR200	1	Door	1
V2-GASKET200	2	Door Gasket	1
***	3	Evaporator	1
V2-PANEL40S	4	Front Panel	1
***	5	Left Top Hinge	1
V2-MAINSWITCH	6	Main Switch	1
V2-CONTROLLER	7	Controller	1
V2-LOCK	8	Lock	1
V2-HINGE01	9	Top Right Hinge	1
***	10	Cabinet	1
***	11	Drier	1
***	12	N/A	***
V2-COND200	13	Condenser	1
***	14	Rear Grille	1
V2-COMP40H	15	Compressor	1
***	16	Compressor board	1
V2-FOOT	17	Adjustable Feet	2
V2-HINGE02	18	Bottom Hinge Right	1
V2-DOORCLOSE	19	Door Closing Stop	1
V2-DOOROPEN	20	Door opening Stop	1

*** Please contact Spares for assistance ***