

# BR1-FISH

Exploded parts diagram

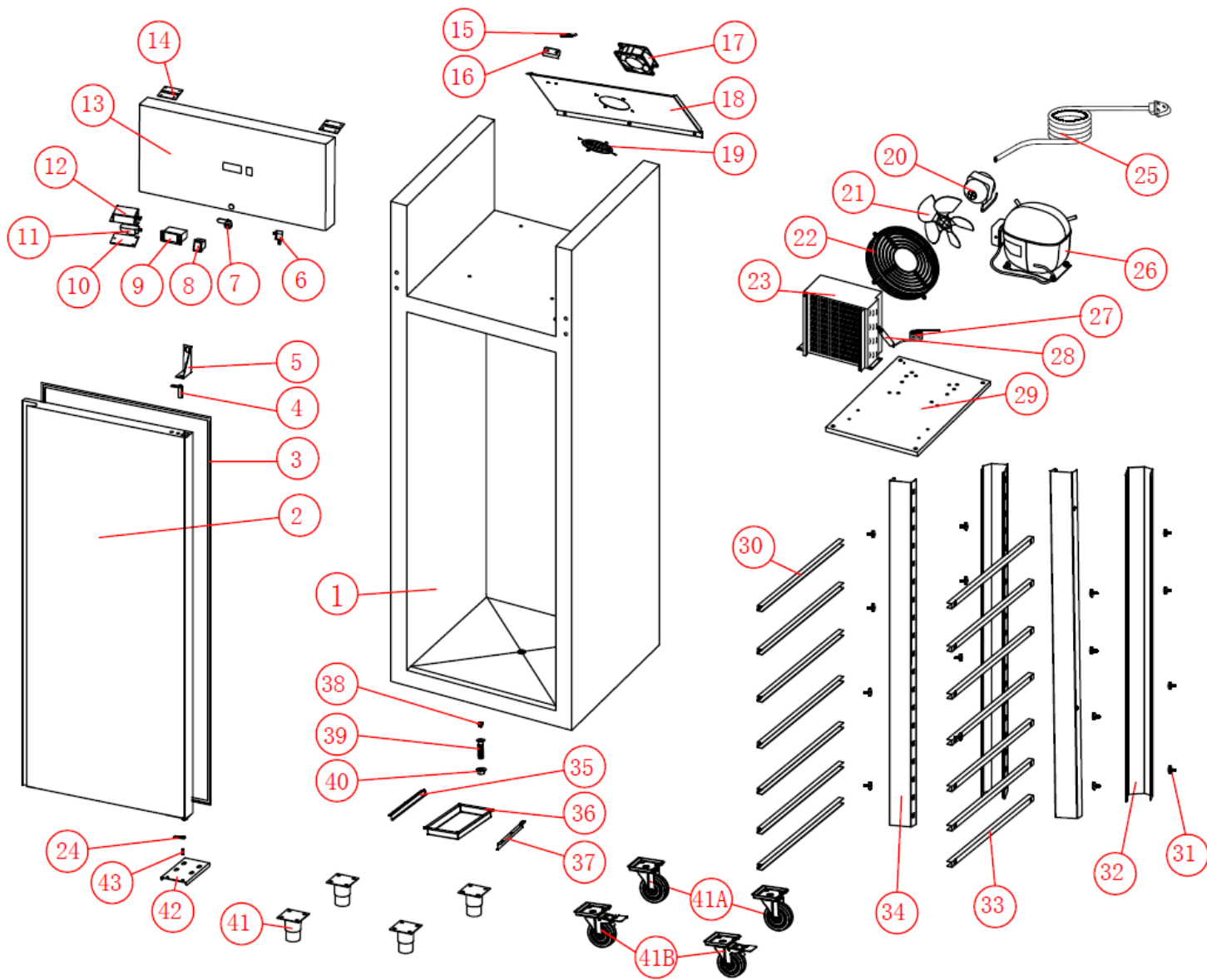





Part Number	Number	Name	Qty
***	1	Cabinet	1
X1-DOOR14	2	Door	1
K8-GASKET03	3	Door Gasket	1
X1-HINGE10	4	Spring Hinge	1
X1-HINGE20	5	RH Upper Hinge	1
X1-SWITCH02	6	Door Switch	1
X1-LOCK04	7	Door Lock	1
X1-SWITCH01	8	Power Switch	1
X1-CONTROLLER03	9	Controller	1
X1-COVER01	10	Light Cover	1
X1-LED04	11	LED Light	1
X1-LIGHTHOLDERBR	12	Light Box	1
X1-PANEL06	13	Top Panel	1
X1-PANELHINGE	14	Top Panel Hinge	2
K8-PROBE02	15	Sensor	1
***	16	Sensor Cover	1
X1-FAN03	17	Evap. Fan	1
***	18	Evap Fan Panel	1
***	19	Evap Fan Guard	1
X1-FAN06	20	Condenser Fan Motor	1
***	21	Condenser Fan Blade	1
***	22	Condenser Fan Guard	1
X1-COND07	23	Condenser	1
X1-HINGEBUSH	24	Hinge Bush	1
***	25	Power Cord	1
X1-COMP07	26	Compressor	1
X1-CAPILLARY03	27	Capillary	1
R4-DRIER20	28	Drier	1
***	29	Cooling Unit Base	1
X1-GUIDE04	30	Shelf Guide (Left)	7
X1-BOLT	31	M5 Racking Bolt	16
***	32	Ladder Rack	2
X1-GUIDE05	33	Shelf Guide (Right)	7
***	34	Ladder Rack	2
***	35	Drain Pan Bracket (Left)	1
X1-DRAINPAN1	36	Drain Pan	1
***	37	Drain Pan Bracket (Right)	1
K8-PLUG	38	Water Plug	1
K8-DRAIN02	39	Drain Spigot	1
K8-DRAIN01	40	Drainpipe Butt	1
***	41	Foot	4
***	42	Castor (Unbraked)	2

***	43	Castor (Braked)	2
X1-HINGE21	44	RH Bottom Hinge	1
X1-HINGEAXIS	45	Bottom Hinge Axis	1
X1-TRAY02	***	Plastic Fish Tray	7

**\*\*\* Please contact Spares for assistance \*\*\***